

MASTER[®]

User's Manual & Operating Instructions

Model Number
MH-600T-KFA



Consumer: Please Read These Instructions And Keep For Your Reference

IMPORTANT: Read and understand all of the directions in this manual before assembling, starting, or servicing the heater. Improper use of this heater can cause serious injury. Keep this manual for future reference.

▲ DANGER GENERAL HAZARD WARNING:

Be sure to comply with the instructions and warnings provided with this heater, or death, serious bodily injury and property loss, damage from the hazards of fire, explosion, burn, asphyxiation, and carbon monoxide poisoning can result.

Only persons who can follow and understand these instructions should use or service this heater. If you need heater information such as an instruction manual, labels, etcetera, contact the manufacturer.

▲ DANGER Not for use in residential living areas or in non-adequately ventilated enclosed spaces.

For outdoor use. Indoor use permitted for: The temporary heating of adequately ventilated buildings or structures under construction, alteration or repair.

Table of Contents

Safety Information	2-3	Long Term Storage	8
Unpacking	3	Maintenance	9-11
Features	3	Wiring Diagram	11
Assembly	4-5	Exploded View	12
Operation	6-8	Replacement Parts	13
Fuels	6	Troubleshooting	14-15
Theory of Operation	6	Warranty	Back Cover
Ventilation	6		

Safety Information

▲ WARNING Fire, burn, inhalation, and explosion hazard. Keep combustibles, such as building materials, paper or cardboard, a safe distance away from the heater as recommended by these instructions. Never use the heater in spaces which contain products such as gasoline, solvents, paint thinners, dust particles, volatile or airborne combustibles, or any unknown chemicals. This is an unvented portable heater. It uses air (oxygen) from the area in which it is used. Adequate combustion and ventilation air must be provided. Refer to VENTILATION on Page 7.

▲ WARNING *Indicates a potentially hazardous situation which, if not avoided, COULD result in death or serious injury.*

▲ CAUTION *Indicates a potentially hazardous situation which, if not avoided, MAY result in minor or moderate injury.*

This is a kerosene, direct-fired, forced air heater. It is primarily intended for use for temporary heating of buildings under construction, alteration or repair. Direct-fired means that all of the combustion products of the heater enter the heated space. This appliance is rated at 98% combustion efficiency, but does produce small amounts of carbon monoxide. Carbon monoxide is toxic.

▲ WARNING Do not operate this heater until you have read, and thoroughly understand these safety and operating instruction. Failure to comply with the precautions and instructions provided with this heater can result in death, serious bodily injury, property loss or damage from the hazards of fire, soot production, explosion, burns, asphyxiation or carbon monoxide poisoning. Only persons who can read and understand these instructions should use or service this heater.

▲ DANGER *Carbon Monoxide poisoning may lead to death!*

Humans can tolerate small amounts of carbon monoxide, and precautions should be taken to provide proper ventilation. Failure to provide proper ventilation according to this manual can result in death. Early signs of carbon monoxide poisoning resemble the flu. Symptoms of improper ventilation are:

- * headache * dizziness * burning of the nose and eyes
- * nausea * dry mouth * sore throat

Not for use in homes or recreational vehicles.

For optimal performance of this heater, it is strongly suggested that 1-K kerosene be used. 1-K kerosene has been refined to virtually eliminate contaminants, such as sulfur, which can cause a rotten egg odor during the operation of the heater. However, #1 or #2 fuel oil (diesel fuel) may also be used if 1-K kerosene is not available. Be advised that these fuels do not burn as clean as 1-K kerosene, and care should be taken to provide more fresh air ventilation to accommodate any added contaminants that may be added to the heated space. Use of #1 or #2 fuel oil may result in more periodic maintenance.

California Residents: Combustion by-products produced when using this product contain carbon monoxide, a chemical known to the state of California to cause cancer and birth defects (or other reproductive harm).

▲ WARNING *Risk of indoor air pollution!*

Massachusetts Residents: Massachusetts state law prohibits the use of this heater in any building which is used in whole or in part for human habitation. Use of this heating device in Massachusetts requires local fire department permit (M.G.L.C. 148, Section 10A).

- Use this heater only in well ventilated areas! Provide at least a three square foot (2,800 sq cm) opening of outside air for every 100,000 BTU/hr of heater rating.

- People with breathing problems should consult a physician before using the heater.

- Carbon Monoxide Poisoning: Early signs of carbon monoxide poisoning resemble flu-like symptoms such as headaches, dizziness, and/or nausea. If you have these symptoms, your heater may not be working properly.

New York City Residents: The New York City Fire Code prohibits the storage, handling and use of kerosene fueled heaters for space heating. Any person violating that provision may be punished by a fine up to \$10,000 and a term of imprisonment up to 6 months.

▲ DANGER *Indicates an imminently hazardous situation which, if not avoided, WILL result in death or serious injury.*

Safety Information (continued)

Simply locate fan in safe, desired position on level ground, and connect to approved power source.

- Get fresh air at once! Have the heater serviced. Some people are more affected by carbon monoxide than others. These include pregnant women, those with heart or lung problems, anemia, or those under the influence of alcohol, or at high altitudes.

▲WARNING *Risk of burns / fire / explosion!*

- NEVER use fuels such as gasoline, benzene, paint thinners, or other oil compounds in this heater (RISK OF FIRE OR EXPLOSION).
- NEVER refill the heater's fuel tank while heater is operating or still hot. This heater is EXTREMELY HOT while in operation.
- Keep all combustible materials away from this heater.
- NEVER block air inlet (rear) or air outlet (front) of heater.
- NEVER use duct work in front or at rear of heater.
- NEVER move or handle heater while still hot.
- NEVER transport heater with fuel in its tank.
- If equipped with a thermostat, the heater may start at any time.
- ALWAYS locate heater on a stable and level surface.

- ALWAYS keep children and animals away from heater.
- Bulk fuel storage should be a minimum of 25 ft. from heaters, torches, portable generators, or other sources of ignition. All fuel storage should be in accordance with federal, state, or local authorities having jurisdiction.
- Never use this heater in living or sleeping areas.
- NEVER use this heater where flammable vapors may be present.

▲WARNING *Risk of electric shock!*

- Use only the electrical power (voltage and frequency) specified on the model plate of the heater. Use only a three-prong, grounded outlet and extension cord.
- ALWAYS install the heater so that it is not directly exposed to water spray, rain, dripping water, or wind.
- ALWAYS unplug the heater when not in use.

Minimum clearance from Combustibles:

Front	10 ft
Top, Sides and Rear	4 ft.

Unpacking

Remove the heater and all of the packaging materials from the shipping carton.

NOTE: Save the box and packaging materials for future storage. Check the chart below to be sure that you have all of the parts

required to assembly your heater. If you find that any parts are missing, call 215-891-8460 for assistance in receiving the missing components.

Features

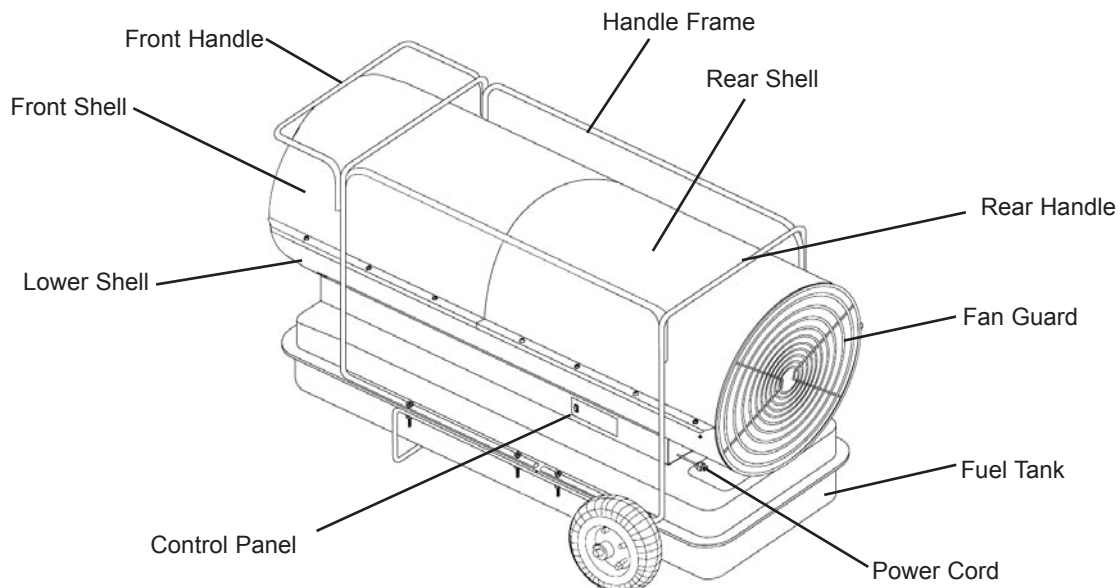

Figure 1: Features of MH-600T-KFA

Assembly

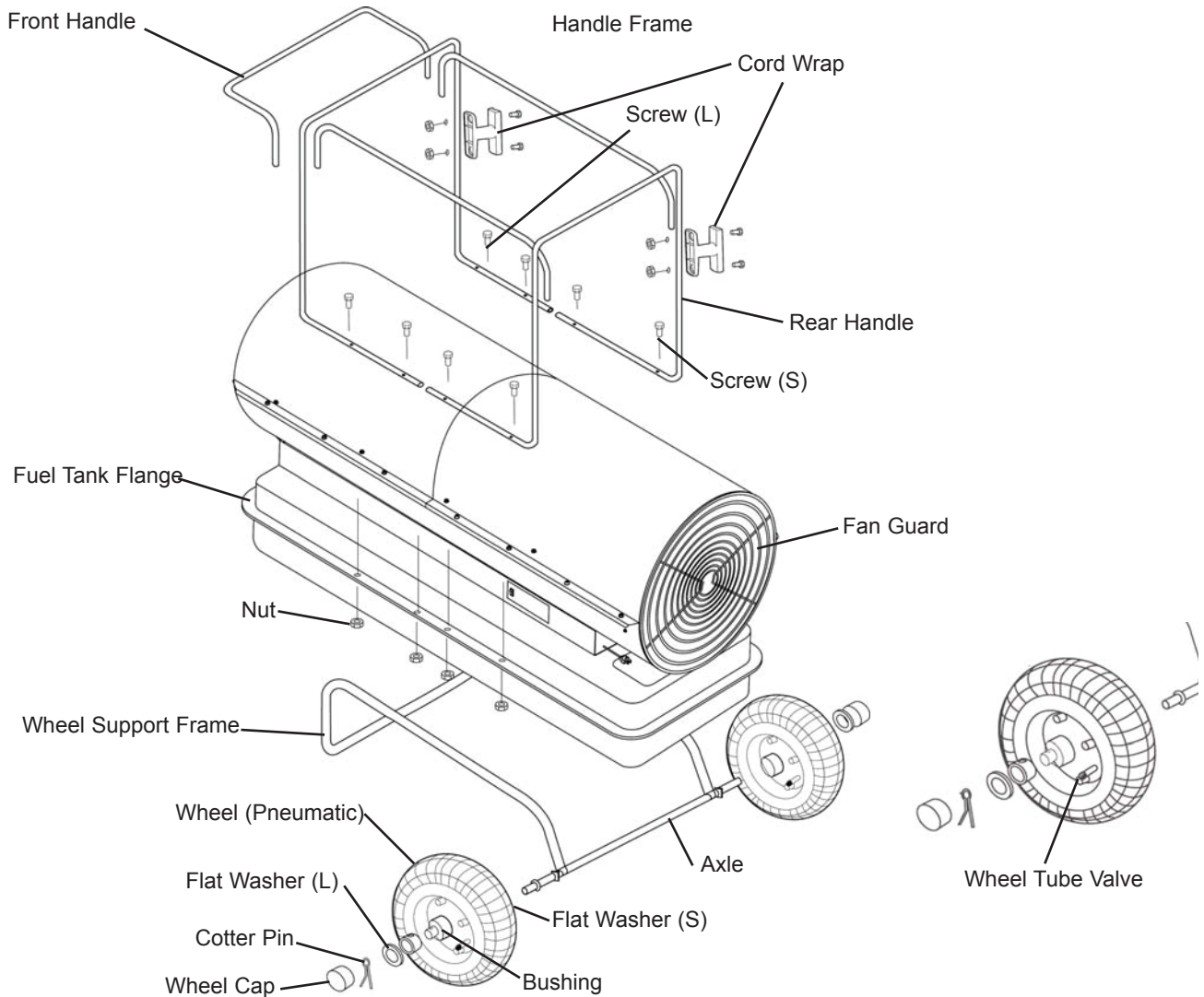

Figure 2: Features of MH-600T-KFA

Assembly (Continued)

	MH-600T-KFA
Wheel support frame	Yes
Wheels and Axle	Yes
Wheel Caps	Yes
Front and Rear Handle	Yes
Cord Wraps	Yes
Handle Frame	Yes
Screws, Nuts and Washers	Yes
Cotter Pins and Bushings	Yes

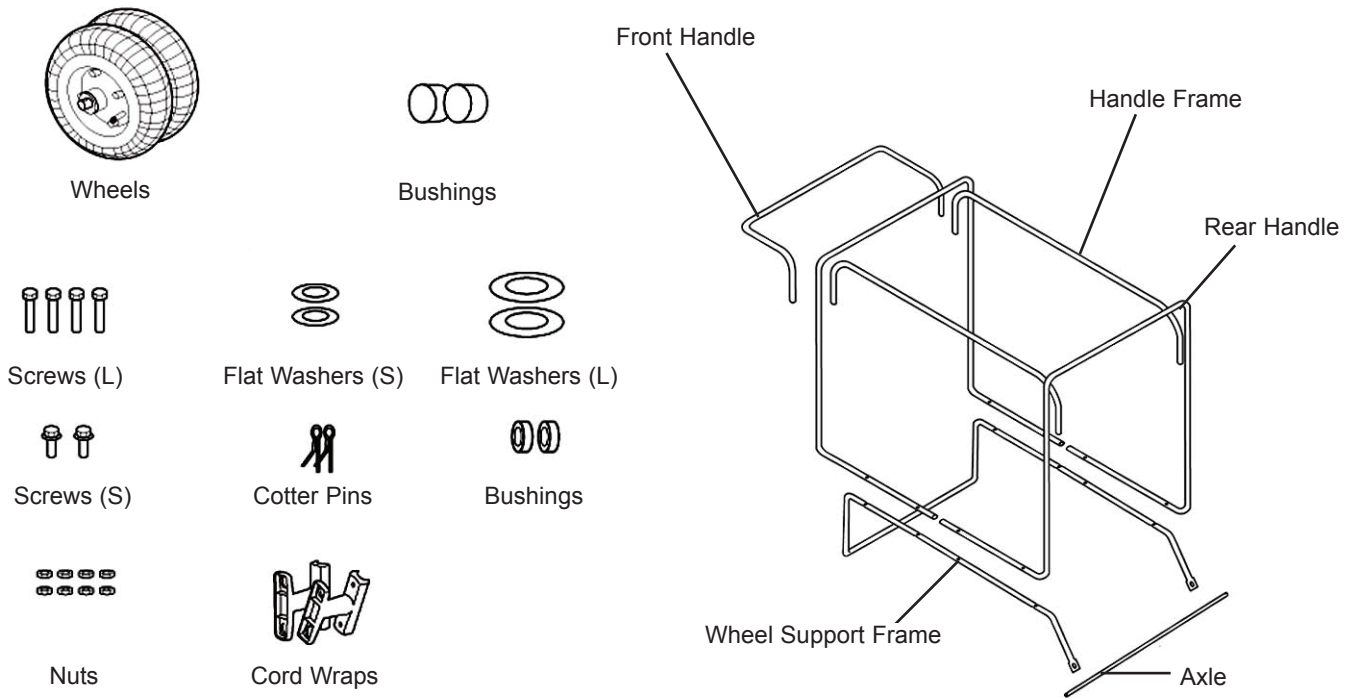

Figure 3: Hardware Components

MH-600T-KFA

- **Tools required:** Medium phillips screw driver, open end or adjustable wrench, needle nose pliers.

ASSEMBLING FRAME AND WHEELS

1. Slide axle through wheel support frame. Install wheel bushings, flat washers (S) and wheel on axle.

NOTE: When installing wheels, tube valve should face out from support frame (Figure 2).

2. Place flat washers (L) and cotter pins on axle ends and bend cotter pins with long nose pliers to secure.

3. Place wheel cap on flat washers (L) and put wheel cap in flat washers (L) end.
4. Place heater on wheel support frame. Make sure air inlet end (rear) of heater is over wheels. Align the holes on fuel tank flange. Insert screws through handles (front and rear), fuel tank flange, and wheel support frame as shown in Figure 3 and attach nut finger tight after each screw is inserted.
5. After all screws are inserted, tighten nuts firmly.

CAUTION DO NOT OPERATE HEATER WITHOUT SUPPORT FRAME FULLY ASSEMBLED TO TANK.

Operation

KEROSENE (1-K)

For optimal performance of this heater, it is strongly suggested that 1-K kerosene be used. 1-K kerosene has been refined to virtually eliminate contaminants, such as sulfur, which can cause a rotten egg odor during the operation of the heater. However, #1 or #2 fuel oil (diesel fuel) may also be used if 1-K kerosene is not available. Be advised that these fuels do not burn as clean as 1-K kerosene, and care should be taken to provide more fresh air ventilation to accommodate any added contaminants that may be added to the heated space. **Using diesel fuel can cause excess soot production.** DO NOT use any fuel that is not approved above.

NOTE: Kerosene should only be stored in a blue container that is clearly marked "kerosene". Never store kerosene in a red container. Red containers are associated with gasoline.

- NEVER store kerosene in the living space. Kerosene should be stored in a well ventilated area outside the living area.
- NEVER use fuel such as gasoline, benzene, alcohol, white gas, camp stove fuel, paint thinners or other oil compounds in this heater (THESE ARE VOLATILE FUELS THAT CAN CAUSE A FIRE OR EXPLOSION).
- NEVER store kerosene in direct sunlight or near a source of heat.
- NEVER use kerosene that has been stored from one season to the next. Kerosene deteriorates over time. OLD KEROSENE WILL NOT BURN PROPERLY IN THIS HEATER.
- Use 1-K kerosene in this heater. #1 fuel is a suitable substitute.

THEORY OF OPERATION

Fuel System: This heater is equipped with a fuel pump that forces fuel through the fuel line connected to the fuel intake, and then through a nozzle in the burner head. This fuel is then sprayed into the combustion chamber in a fine mist.

Quick-Fire Ignition: The electronic ignitor sends voltage to a specially designed spark plug. The spark plug ignites the fuel and air mixture.

Air System: The heavy duty motor turns a fan that forces air into and around the combustion chamber. Here, the air is heated and then forced out the front of the heater.

Temperature Limit Control: This heater is equipped with a Temperature Limit Control designed to turn the heater off should the internal temperature rise to an unsafe level. If this device activates and turns your heater off, it may require service.

Once the temperature falls below the reset temperature, you will be able to start your heater.

Electrical System Protection: This heater's electrical system is protected by a fuse that protects it and other electrical components from damage. Fuse is located inside of an in-line "FUSE BARREL". If your heater fails to operate, check this fuse first and replace as needed.

Flame Sensor: Utilizes a photocell to monitor the flame in burn chamber during normal operation. It will cause the heater to shut off should the burner flame extinguish.

FUELING THE HEATER

It is always a good idea to fire the heater outdoors for the first time. This will allow any oils used in the manufacturing process to be burned off in a safe environment. This initial burn should last at least 10 minutes.

▲ WARNING NEVER REFUEL THIS HEATER WHILE IT IS HOT OR OPERATING. FIRE OR EXPLOSION COULD RESULT.

▲ CAUTION NEVER FILL THE FUEL TANK INDOORS. ALWAYS FILL THE TANK OUTDOORS. BE SURE THAT THE HEATER IS ON LEVEL GROUND WHEN FUELING, AND NEVER OVERFILL THE FUEL TANK.

VENTILATION

▲ CAUTION *Risk of indoor air pollution. Use heater only in well ventilated areas.*

Always provide a fresh air opening in the heated space of at least three square feet (2,800 sq. cm) for each 100,000 BTU/Hr. of heater output. Provide a larger opening if more heaters are being used.

TO START HEATER

1. Fill fuel tank with 1-K kerosene or No. 1 fuel oil.
2. Attach fuel cap and be sure it is secure.
3. Plug power cord into three prong, grounded extension cord and plug extension cord into three prong 120V grounded outlet. The extension cord should be at least six feet long.

Extension Cord Wire Size Requirements:

- 6 to 10 feet long, use 14 AWG conductor.
 - 101 to 200 feet long, use 12 AWG conductor.
 - 201 to 300 feet long, use 10 AWG conductor.
 - 301 to 400 feet long, use 8 AWG conductor.
 - 401 to 500 feet long, use 6 AWG conductor.
4. Push "OPERATION BUTTON". Power indicator lamp and room temperature display will light and heater will start. Push the up and down arrow keys on the control panel to adjust the thermostat setting.

Operation (Continued)

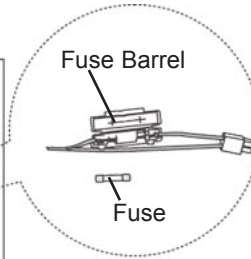
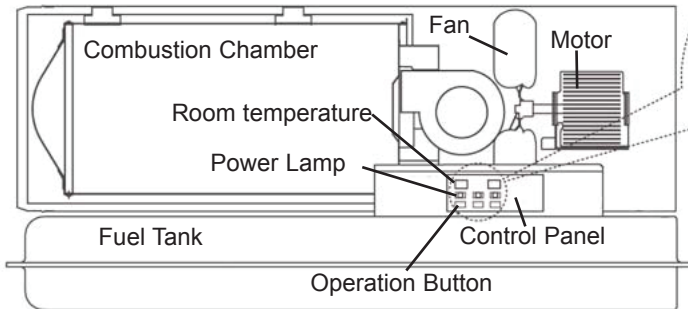

MODEL	MH-600T-KFA
Internal Shut-Off Temp. +/-10 Degrees	176°F / 80°C
Reset Temp. +/-10 Degrees	149°F / 65°C

Figure 4: Overview of Heater design

If heater does not start, the thermostat setting may be too low. Push "TEMP CONTROL UP ARROW" to higher setting to start heater. If heater still does not start, see Troubleshooting Chart on page 14.

NOTE: The major electrical components of this heater are protected by a circuit breaker (fuse) mounted to the power switch. If your heater fails to start, check this first and replace as necessary. You should also check your power source to insure that proper voltage and frequency are being supplied to the heater.

TO STOP HEATER

▲ WARNING *Never unplug heater while heater is running!*

Heater must go through cooling cycle. The cooling cycle cools the combustion chamber. Damage to heater can occur if combustion chamber is not cooled. Do not restart heater until cooling cycle is complete.

1. Push "OPERATION BUTTON", This will cause heater flame to go out. The motor will continue to run during the cooling cycle. This allows the fan to cool the combustion chamber. When the cooling cycle (approx. 2 minutes) is finished, the motor will stop.

Do not unplug heater until cooling cycle is finished.

2. Disconnect heater from power source.

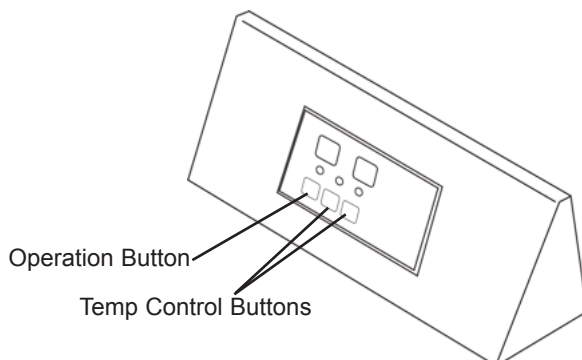

Figure 5: Control Panel

3. To temporarily stop heater, set thermostat at a temperature lower than air around heater. Heater will cycle back on if air temperature around heater matches thermostat setting.

TO RESTART THE HEATER

▲ CAUTION *Do not restart heater until cooling cycle is finished.*

1. Wait until after cooling cycle has finished after stopping heater.
2. Repeat steps under TO START HEATER.

ELECTRICAL OUTLET

▲ WARNING **Shock Hazard!**

- Never plug in an appliance with more than 5amp rating in this outlet.
- Always keep outlet covered when not in use
- 120V 5amp max (non fused).

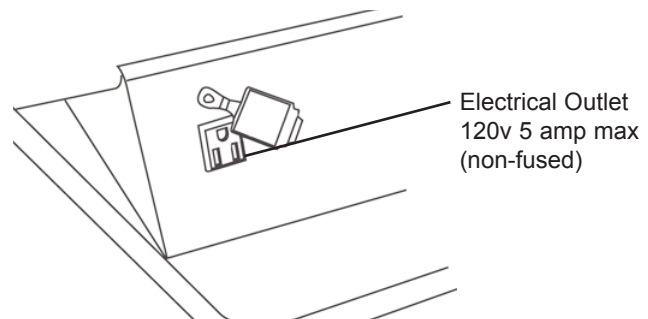

Figure 6: Electrical Outlet

Operation (Continued)

LONG TERM STORAGE

Drain Fuel Tank

1. Remove drain nut from rear bottom side of fuel tank by unscrewing nut and drain. See Figure 7.
2. Using a small amount of kerosene, swirl and rinse the inside of the tank.

NEVER MIX WATER WITH KEROSENE, as it will cause rust inside the tank. Pour the kerosene out, making sure that you remove it all.

IMPORTANT: Do not store kerosene over summer for use during next heating season. Using old fuel may damage heater.

IMPORTANT: Never store leftover kerosene over the summer. Using old fuel can damage your heater.

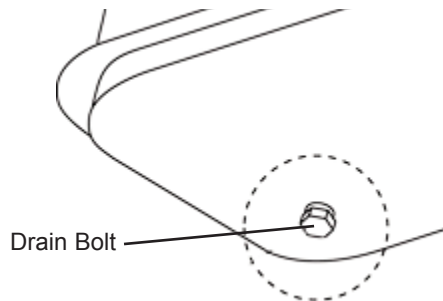

Figure 7: Drain Bolt

3. Reinstall drain bolt as follows:

- Insert bolt's seal head fully into drain hole so that flange is flush to tank's bottom.
- Insert seal cap fully into head hole so that cap flange is flush to head flange.

IMPORTANT: Reinstall bolt fully into hole in tank; otherwise it will not seal completely.

- Make sure storage place is free of dust and corrosive fumes.
- Store the heater in the original box with the original packing material and keep USER'S MANUAL with heater.

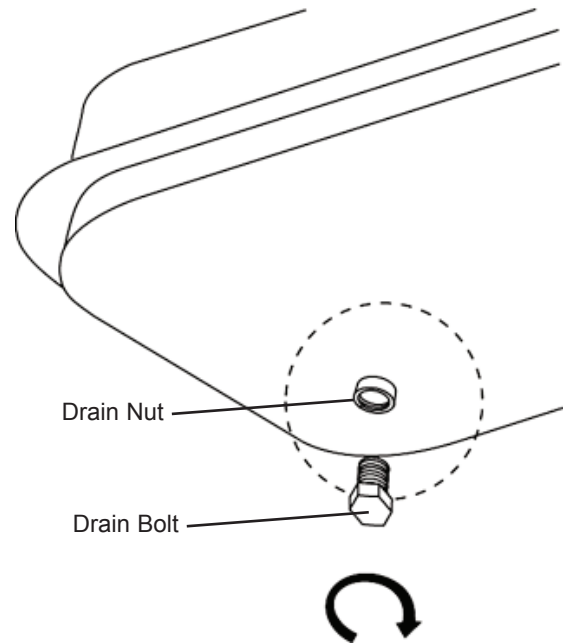
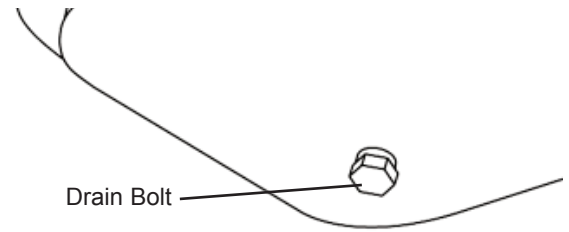

Figure 8: Drain Bolt Reinstall

Maintenance

▲ WARNING *Never service heater while it is plugged in or while hot!*

Use only original equipment replacement parts. The use of alternate or third party components can cause unsafe operating conditions, and will void your warranty.

We suggest following a maintenance schedule as follows:

FUEL/FUEL TANK:

Flush every 200 hours of operation or as needed. Do not use water to flush the tank. Use fresh 1-K kerosene only.

AIR FILTERS:

The *Air Intake Filter* should be replaced or washed with soap and water and dried thoroughly every 500 hours of operation, or less, depending on conditions.

The *Output* and *Lint Filters* should be replaced every 500 hours of operation or less, depending on conditions.

NOTE: Use of diesel may require additional maintenance.

FAN BLADES:

CLEAN EVERY SEASON OR AS NEEDED.

- Remove upper shell (See air intake filter).
- Use Allen wrench to loosen set screw which holds fan blade to motor shaft.
- Slip fan blade off motor shaft.
- Clean fan blade using soft cloth moistened with kerosene or solvent.
- Dry fan blade thoroughly.
- Reinstall fan blade to motor shaft.
- Place fan hub flush with end of motor shaft.
- Place set screw on flat end of shaft.
- Tighten screw firmly (40-50 inch pounds/ 4.5-5.6 N-m). Reinstall upper shell.

NOZZLE:

Remove dirt in nozzle as needed

- Remove upper shell.
- Remove fuel line B from burner assembly by using wrench.
- Remove burner head from burner assembly.
- Remove lead wire from spark plug.
- Remove spark plug from burner head.
- Carefully remove nozzle from burner head using socket wrench.
- Blow compressed air through face of nozzle (This will remove any dirt).
- Inspect nozzle for damage. If damaged or clogged, replace nozzle.
- Make sure plug is in place on burner head.

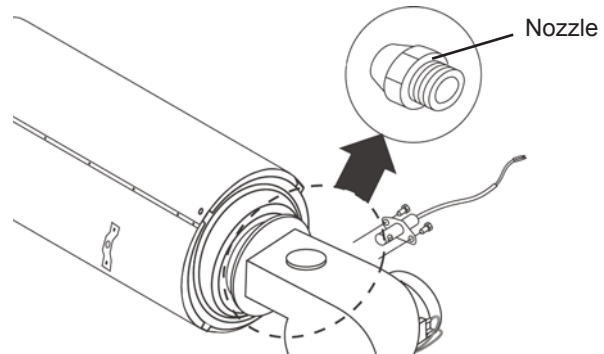

Figure 9: Nozzle Replacement

- Reinstall nozzle into burner head and tighten firmly (175-200 inch-pounds).
- Reinstall spark plug in burner head.
- Attach burner head to combustion chamber.
- Attach spark plug wire to spark plug
- Attach fuel line to burner head and tighten firmly.
- Replace upper shell.
- Attach ignitor wire to spark plug.
- Attach fuel and air line hoses to burner head.
- Reinstall fan blade and upper shell.

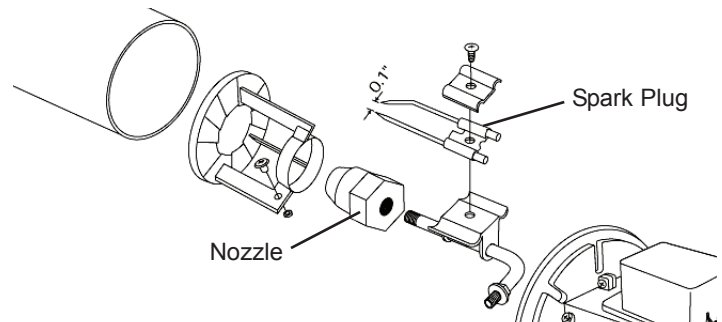

Figure 10: Spark Plug Replacement

SPARK PLUG:

CLEAN AND REGAP EVERY 600 HOURS OF OPERATION OR REPLACE AS NEEDED.

- Remove upper shell.
- Remove spark plug wire from spark plug.
- Remove spark plug from burner head using medium Phillips screwdriver.
- Clean and regap spark plug electrodes to 0.1" (2.5 mm) gap.
- Reinstall spark plug into burner head.
- Attach spark plug wire to spark plug.
- Reinstall upper shell.

Maintenance (Continued)

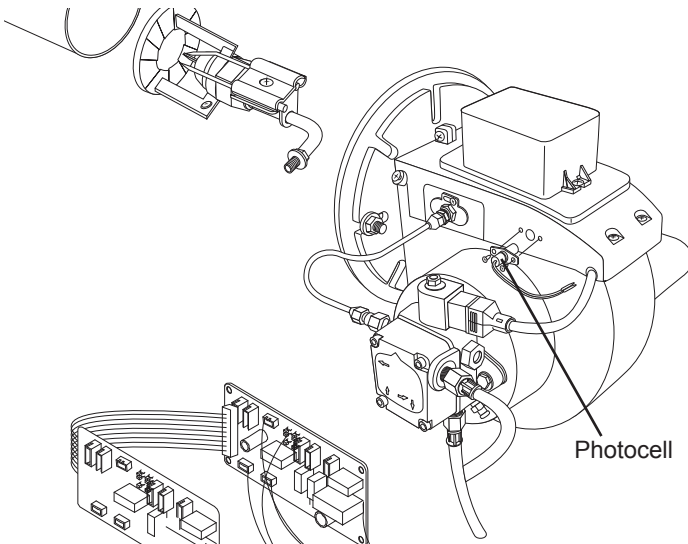

Figure 11: Photocell

PHOTOCELL:

CLEAN PHOTOCELL ANNUALLY OR AS NEEDED.

- Remove upper shell.
- Remove fan (See fan blades on page 9).
- Remove photocell from its mounting bracket
- Clean photocell lens with cotton swab.

TO REPLACE: Remove side cover near Operation switch.

- Disconnect wires from Operation switch and remove photocell.
- Disconnect wires from circuit board and remove side cover.
- Install new photocell and attach wires to circuit board.
- Replace switch wires to operation switch and side cover.
- Replace fan and upper shell.

FUEL FILTER:

CLEAN TWICE PER HEATING SEASON OR AS NEEDED.

- Open rear shell.
- Remove filter cover by unscrewing four screws (see Figure 12).
- Remove fuel filter from filter cover.
- Wash fuel filter in clean kerosene.
- Replace fuel filter and filter cover.

Fuel filter A in fuel tank:

- Remove fuel cap (see Figure 13).
- Take out fuel filter from fuel tank.
- Wash fuel filter A with clean kerosene.
- Replace fuel filter in fuel tank.
- Replace fuel cap on fuel tank.

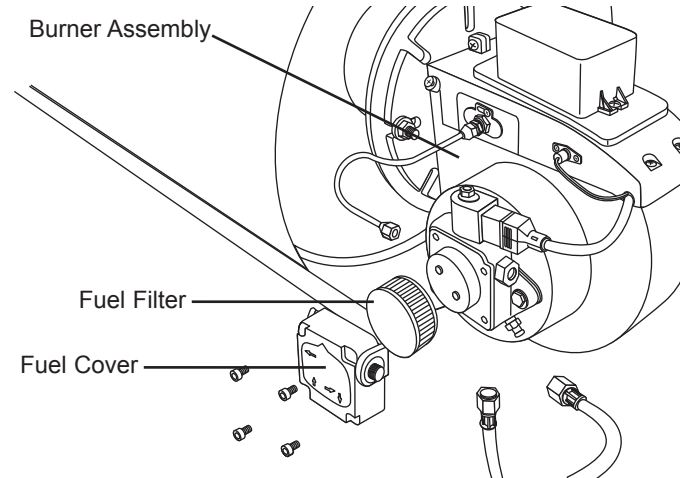

Figure 12: Removing Fuel Filter

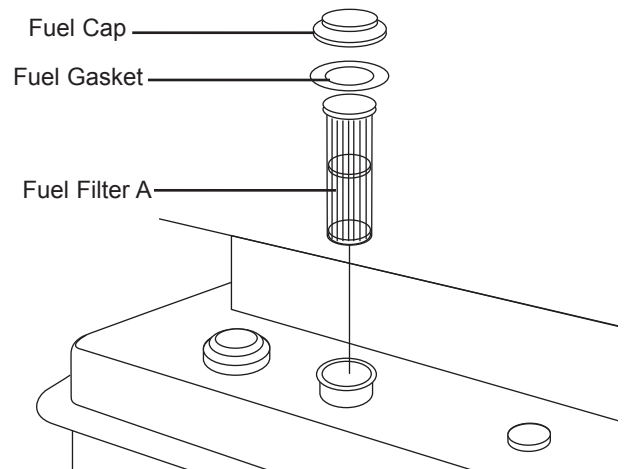

Figure 13: Fuel Filter A in Tank

PUMP PRESSURE ADJUSTMENT:

- Remove rear shell.
- Remove fuel line A from fuel pump by using wrench.
- Replace pressure gauge at outlet of fuel pump.
- Adjust pump pressure by turning pressure adjustment screw
- Replace pressure gauge at outlet of fuel pump.
- Adjust pump pressure by turning pressure adjustment screw.
- Turn relief valve clockwise to increase pressure.
- Turn relief valve counterclockwise to decrease pressure.
- Set pump pressure to 128 PSI by turning screwdriver.

Pump pressure gauge is not supplied.

Maintenance (Continued)

NOTE: Use only original equipment replacement parts. Use of alternate or third party components will void any warranty and may cause unsafe operating conditions.

- Stop heater (See OPERATION, page 6).
- If accessory pressure gauge is being used, remove pressure gauge.
- Replace pressure gauge, and plug in end of filter cover.

NOTE: If heater does not ignite when heater is turned on, please turn AIR VENT SCREW counter clockwise to release air, then turn OPERATION SWITCH back on.

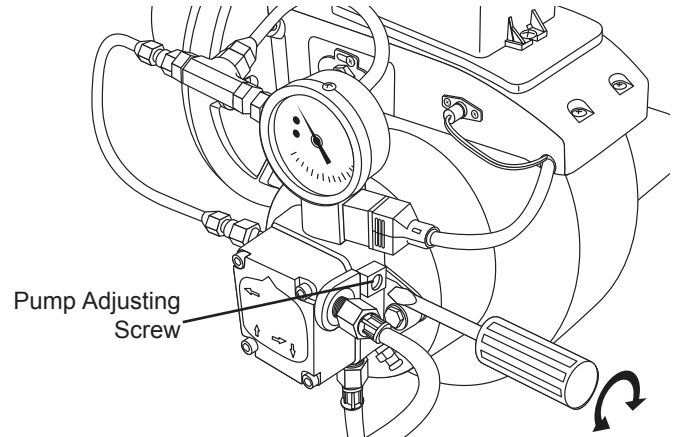

Figure 14: Pump Pressure Adjustment

Wiring Diagram

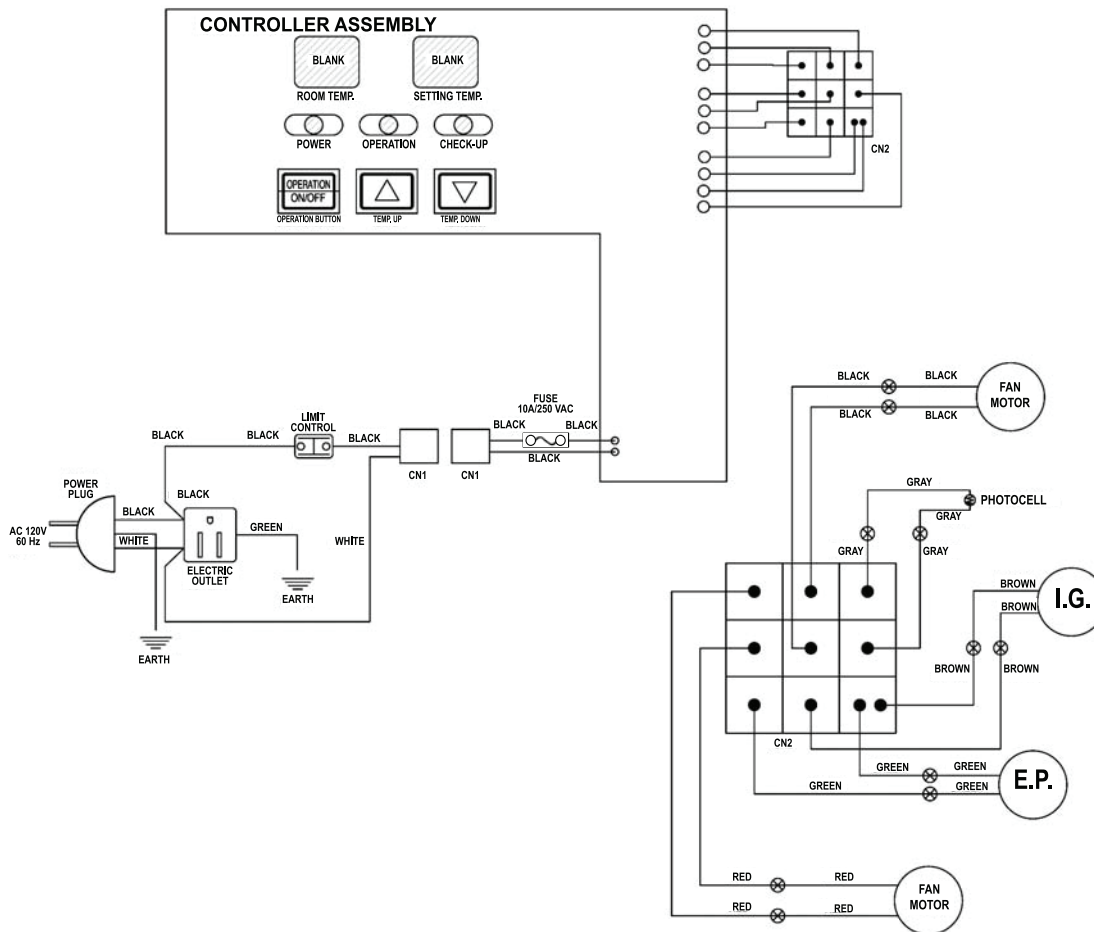

Figure 15: Wiring Diagram for MH-600T-KFA

Exploded View

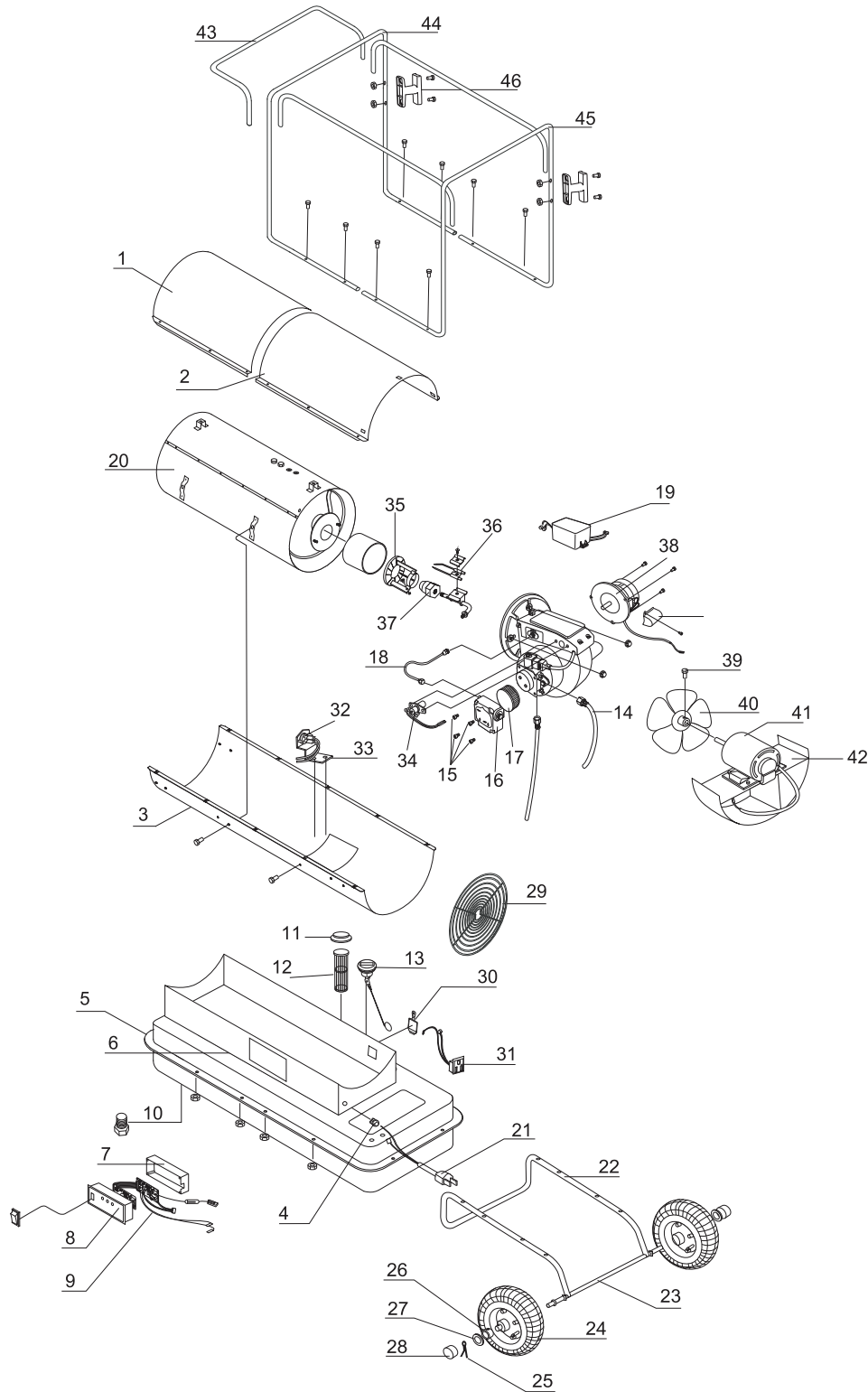

Figure 16: Exploded View for MH-600T-KFA

Parts List

Item #	Description	MH-600T-KFA	Item #	Description	MH-600T-KFA
1	Upper Front Shell	—	24	Wheel	70-041-0113
2	Upper Rear Shell	—	25	Cotter Pin	70-041-0107
3	Lower Shell	—	26	Wheel Bushing	70-041-0109
4	Cord Bushing	70-033-0200	27	Flat Washer	70-041-0105
5	Fuel Tank	—	28	Wheel Cap	70-041-0111
6	Right Side Cover	70-008-0610	29	Safety Guard	70-065-0200
7	PCB Case	70-027-0801	30	Socket Cover	70-030-0100
8	PCB Assembly	70-027-0800	31	Electric Outlet Assembly	70-029-0100
9	PCB Lead Wire	70-027-0802	32	Thermostat	70-019-0500
10	Drain Plug	70-002-0107	33	Thermostat Bracket	70-019-0501
11	Fuel Cap Assembly	70-006-0200	34	Photocell	70-016-0160
12	Fuel Filling Filter	70-006-0300	35	Burner Head	70-014-0800
13	Fuel Gauge	75-007-0400	36	Spark Plug	70-052-0500
14	Fuel Line	70-036-1000	37	Nozzle	70-015-0800
15	Fuel Filter Cover Screw	70-006-0502	38	Burner Motor	70-063-0201
16	Fuel Filter Cover	70-006-0503	39	Fan Fixing Screw	70-024-0805
17	Fuel Filter	70-006-0501	40	Fan Assembly	70-024-0800
18	Drain Line	70-036-1001	41	Fan Motor Assembly	70-021-0800
19	Ignitor	70-037-0800	42	Motor Supporter	70-020-0408
20	Combustion Chamber	—	43	Front Handle	70-042-0400
21	Power Cord	70-034-0300	44	Handle Frame	70-042-0401
22	Wheel Support Frame	70-064-0200	45	Rear Handle	70-043-0400
23	Wheel Axle	70-041-0403	46	Cord Wrap	70-032-0200

Troubleshooting

Symptom	Possible Cause(s)	Solution
E1	<ol style="list-style-type: none"> 1. Wrong pump pressure 2. Dirty fuel filter 3. Dirt in nozzle 4. Dirty photocell lens 5. Photocell assembly not properly installed (not seeing flame) 6. Bad electrical connection between photocell and Main PCB assembly 7. Defective photocell 	<ol style="list-style-type: none"> 1. See Pump Pressure Adjustment, Page 10 2. See Fuel Filter, Page 10 3. See Nozzle, Page 9 4. Clean Photocell Lens, Page 9 5. Make sure photocell boot is properly seated in bracket (See page 10) 6. Check electrical components (See Wiring Diagrams, Page 11) 7. Replace Photocell, Page 10
E1	<p>Heater will not ignite, but motor runs for a short period of time (Lamp is flickering)</p> <ol style="list-style-type: none"> 1. No fuel in tank 2. Wrong pump pressure 3. Carbon deposits on spark plug and/or improper gap 4. Dirty fuel filter 5. Dirt in nozzle 6. Water in fuel tank 7. Bad electrical connection between ignitor and Main PCB assembly 8. Ignitor Wire not attached to spark plug 9. Defective ignitor 	<ol style="list-style-type: none"> 1. Fill tank with kerosene 2. See Pump Pressure Adjustment, Page 10 3. See Spark Plug, Page 9 4. See Fuel Filter, Page 10 5. See Nozzle, Page 9 6. Flush fuel tank with clean kerosene, page 7 7. Check electrical connections (See Wiring Diagrams, Page 11) 8. Attach ignitor wire to spark plug (See Spark Plug, Page 9) 9. Replace ignitor
E1 or E2	<p>Fan does not turn when heater is plugged in.</p> <ol style="list-style-type: none"> 1. Thermostat setting too low 2. Poor electrical connection between motor and Main PCB assembly 	<ol style="list-style-type: none"> 1. Adjust thermostat to a higher setting 2. Check electrical connections (See Wiring Diagrams, Page 11)
E3	<ol style="list-style-type: none"> 1. Switch Failure 2. Short Circuit 	<ol style="list-style-type: none"> 1. Replace Switch 2. Check Wiring and connection

Troubleshooting (Continued)

Symptom	Possible Cause(s)	Solution
E4	Sensor disconnected	A. Check limit control thermostat B. Check sensor connection
E5	Temperature limit safety device is overheated	1. Wait until unit cools down
Other Problems	1. Poor Combustion - Flames extending beyond heater - Low heat output 2. Power Failure - No power supply to heater	1. Poor Combustion - Adjust Pump Pressure (see page 10) 2. Power Failure - Check / Replace Fuse



NEVER LEAVE HEATER UNATTENDED WHILE BURNING OR WHILE CONNECTED TO A POWER SOURCE

LIMITED WARRANTY

Pinnacle Products International, Inc. warrants this heater to the original retail purchaser only, to be free from defects in material and workmanship for a period of one (1) year from the date of initial purchase. This product must be properly installed, maintained and operated in accordance with the instructions provided.

Pinnacle Products International, Inc. requires reasonable proof of your date of purchase from an authorized retailer or distributor. Therefore, you should keep your sales slip, invoice, or cancelled check from the original purchase. This Limited Warranty shall be limited to the repair or replacement of parts, which prove defective under normal use and service within the warranty period, and which **Pinnacle Products International, Inc.** shall determine at its reasonable discretion.

This warranty does not apply to products purchased for rental use.

This Limited Warranty does not cover any failures or operating difficulties due to normal wear and tear, accident, abuse, misuse, alteration, misapplication, improper installation or improper maintenance and service by you or any third party. Failure to perform normal and routine maintenance on the heater, shipping damage, damage related to insects, birds, or animals of any kind, and damage due to weather conditions are also not covered. In addition, the Limited Warranty does not cover damage to the finish, such as scratches, dents, discoloration, rust or other weather damage, after purchase.

All transportation costs for the return of the damaged product or parts will be the responsibility of the purchaser. Upon receipt of damaged item, **Pinnacle Products International, Inc.** will examine the item and determine if defective. **Pinnacle Products International, Inc.** will repair or replace and return the item, freight pre-paid. If **Pinnacle Products International, Inc.** finds the item to be in normal operating condition, or not defective, the item will be returned freight collect. This Limited Warranty is in lieu of all other express warranties. **Pinnacle Products International, Inc.** disclaims all warranties for products that are purchased from sellers other than authorized retailers or distributors.

AFTER THE PERIOD OF THE ONE (1) YEAR EXPRESS WARRANTY EXPIRES, **Pinnacle Products International, Inc.** DISCLAIMS ANY AND ALL IMPLIED WARRANTIES, INCLUDING WITHOUT LIMITATION THE IMPLIED WARRANTIES OF MERCHANTABILITY AND FITNESS FOR A PARTICULAR APPLICATION. FURTHER, **Pinnacle Products International, Inc.** SHALL HAVE NO LIABILITY WHATSOEVER TO PURCHASER OR ANY THIRD PARTY FOR ANY SPECIAL, INDIRECT, PUNITIVE, INCIDENTAL, OR CONSEQUENTIAL DAMAGES. **Pinnacle Products International, Inc.** assumes no responsibility for any defects caused by third parties. This Limited Warranty gives the purchaser specific legal rights; a purchaser may have other rights depending upon where he or she lives. Some states do not allow the exclusion or limitation of special, incidental or consequential damages, or limitations on how long a warranty lasts, so the above exclusion and limitations may not apply to you.

Pinnacle Products International, Inc. does not authorize any person or company to assume for it any other obligation or liability in connection with the sale, installation, use, removal, return, or replacement of its equipment, and no such representations are binding on **Pinnacle Products International, Inc.**

Always be sure to specify model number and serial number when making any claim with **Pinnacle Products International, Inc.** For your convenience use the space provided below to list this information:

Model #: _____

Serial #: _____

Date of Purchase: _____